

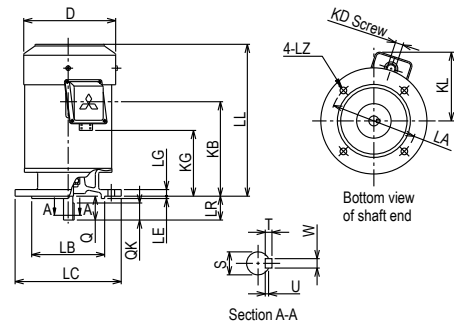

Outline Drawing



Specifications

Output Power HP (kW)	1 (0.75)
Phase	3 Phase
Pole	4 Pole
Frame Number	80M

Degrees of Protection	IP 55
Enclosure Construction	Totally-enclosed Fan-cooled
Thermal Class	Class F (155 °C)

Alignment	Vertical
Frame Material	Steel plate

Power Transmission	Direct-couple or Belt Driven
Direction of Rotation	Counterclockwise (CCW) viewed from shaft-end side

Connection Type	Terminal Block (6 Leads)
Coating Colour	Munsell N5.5 (Gray)
Conformed Standard	IEC 60034-1 & JEC-2137-2000

Voltage & Frequency	LT Type
	220/380~415V 50Hz 220/440V 60Hz

Motor Characteristics

Type	Hz	V	50% Load			75% Load			100% Load				Torque(%)		Is (A)	Inertia GD ² (kg-m ²)	
			(A)	Eff(%)	PF(%)	(A)	Eff(%)	PF(%)	(A)	Eff(%)	PF(%)	Speed (r/min)	Torque (kg-m)	Ts			Tm
LT	50	220	2.19	0.74	0.61	2.61	0.77	0.73	3.14	0.78	0.80	1400	0.520	317	275	18.1	0.0109
		380	1.26	0.74	0.61	1.51	0.78	0.73	1.81	0.78	0.80	1400	0.520	317	275	10.5	
		415	1.44	0.70	0.52	1.62	0.75	0.65	1.86	0.76	0.74	1410	0.520	380	328	11.3	
	60	220	1.84	0.77	0.69	2.32	0.80	0.80	2.91	0.80	0.85	1700	0.430	263	237	15.6	
		440	1.20	0.70	0.58	1.40	0.75	0.70	1.65	0.76	0.78	1720	0.420	355	322	10.5	

Dimensions (mm)

Flange Number	Motor							
	D	LA	LB	LC	LE	LG	LL	LZ
FF165	166	165	130 j6	200	3.5	12	226	12

Terminal Box			Shaft End						
KD	KG	KL	LR	Q	QK	S	T	U	W
PF 3/4	78	144	40	40	32	19 j6	6	3.5	6

Bearing No.		Approximated Weight (kg)	Approximated Packing Dimensions (LxWxH)	Gross Weight (kg)
Drive End	Opposite			
6204ZZ	6203ZZ	13	368 x 280 x 226	14.5

Connection & Connection Diagram

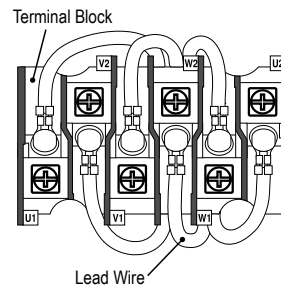

Connection

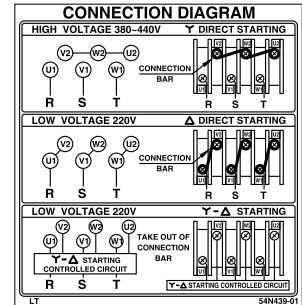

Connection Diagram

Circumstance Conditions

Ambient Temperature	-20 ~ +40°C
Ambient Humidity	95% RH or less
Operating Altitude	Less than 1,000m above sea level
Environment	No bursting / erosive gas or vapor